

# KENAY

ROUND CAMA /  
ROUND BED

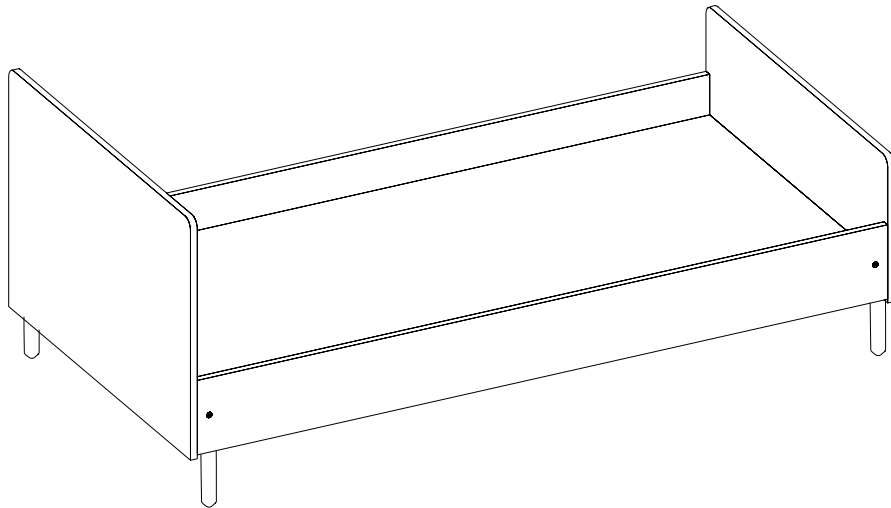





KAN-1335BL / KAN-1335FI /  
KAN-1335PA



Es muy importante seguir las fases de montaje y utilizar todos los herrajes enviados por fábrica.  
 It is very important to follow every assembly stage and use all hardware shipped by factory.

## PIEZAS / PIECES

## HERRAMIENTAS / TOOLS

A x 4 	B x 4 	C x 4 	D x 4 		
E x 4  Tapón 25 mm / cap 25 mm	F x 5  M8 x 35 mm	G x 5 	H x 4  Tapón 19 mm / cap 19 mm	I x 16  Ø4 x 20 mm	J x 4 

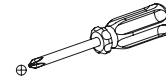

1. Revisar las piezas que constituyen el mueble.
2. Agrupar por tipos los herrajes.
3. Preparar los útiles necesarios.
4. Proteger la zona de montaje (moqueta o similar) para la protección de la madera.
5. Iniciar el montaje (no forzar los ensamblajes).
6. Se advierte de los riesgos inherentes a una instalación incorrecta.
7. Limpiar el polvo con un trapo seco y suave. No utilizar alcohol, disolventes u otros productos químicos

1. Check each piece which forms the furniture.
2. Group by type of fitting.
3. Prepare the necessary tools.
4. Prepare the assembly area (carpet or similar) to protect the wood.
5. Begin the assembly (do not force the connections).
6. Be warned of risks due to incorrect installation.
7. Wipe off dust with a soft, dry cloth. Do not use alcohol, solvents or other chemicals.

## PARTES / PARTS

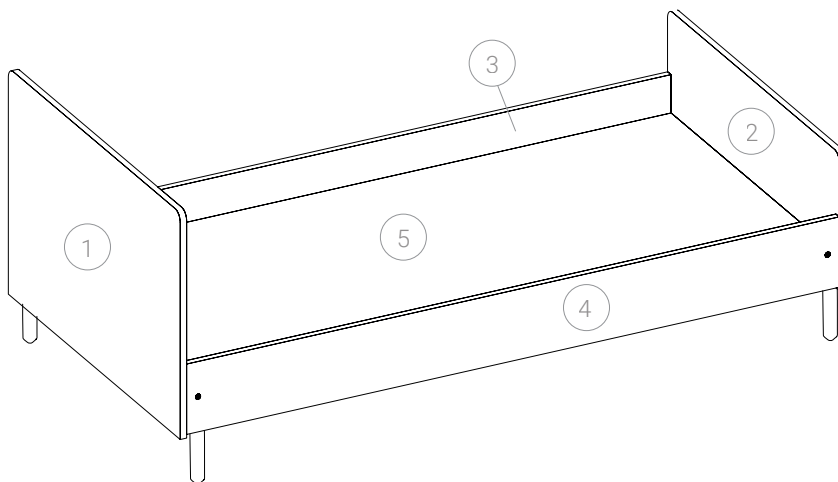

- ① x 1 ud.
- ② x 1 ud.
- ③ x 1 ud.
- ④ x 1 ud.
- ⑤ x 1 ud.

## PASO 1 / STEP 1

A x 4

D x 4

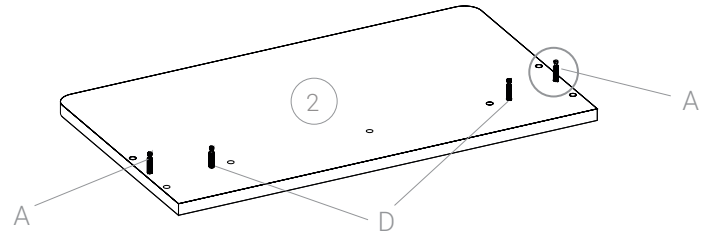
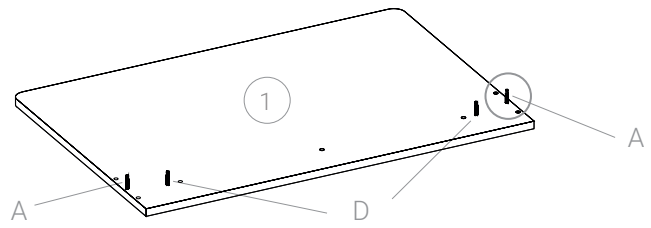
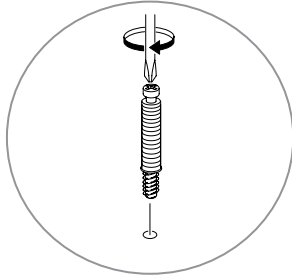
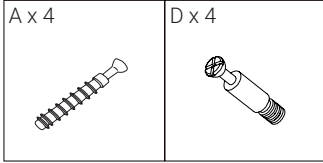

## PASO 2 / STEP 2

B x 2

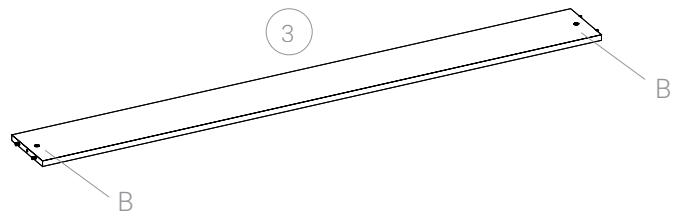
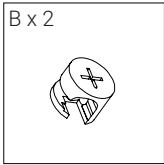

## PASO 3 / STEP 3

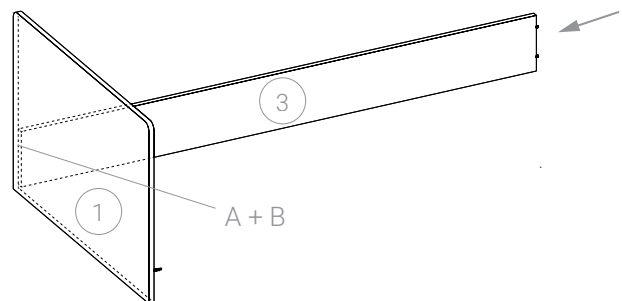
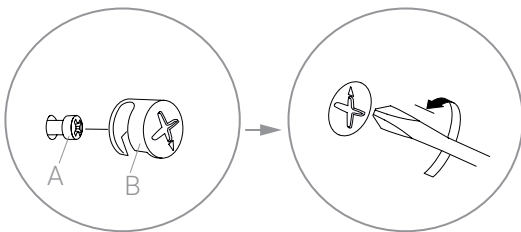

## PASO 4 / STEP 4

C x 4

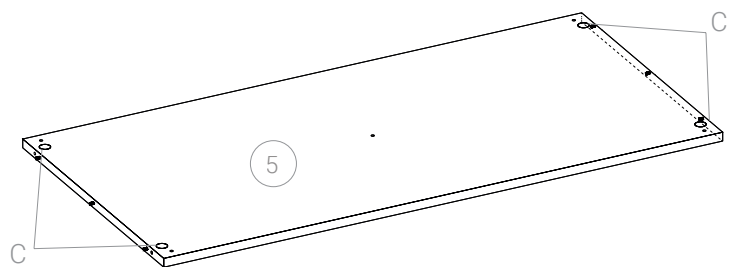
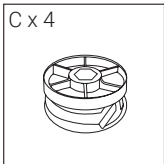

PASO 5 / STEP 5

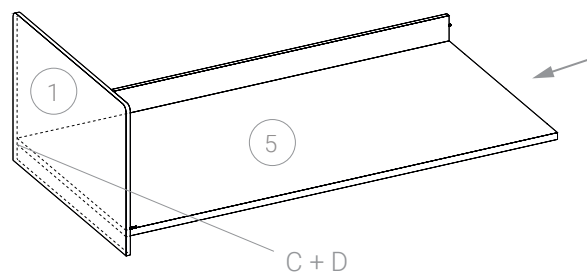
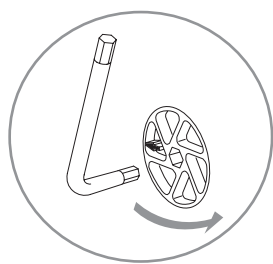

PASO 6 / STEP 6

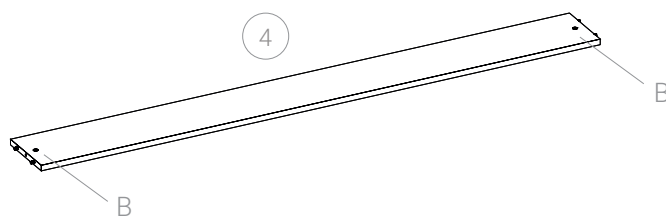
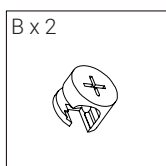

PASO 7 / STEP 7

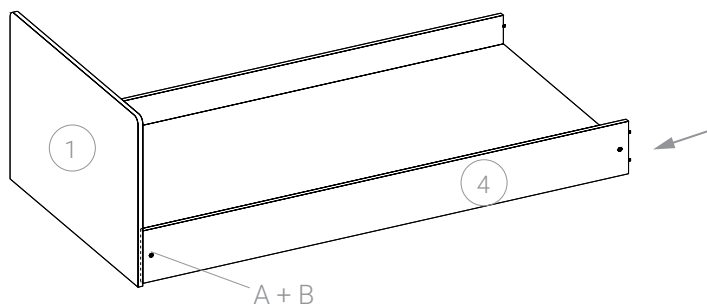
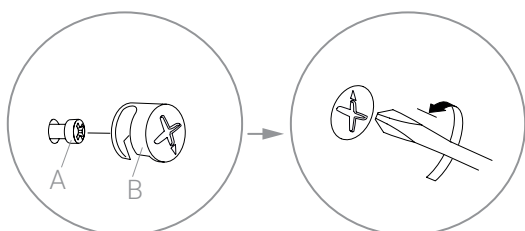

PASO 8 / STEP 8

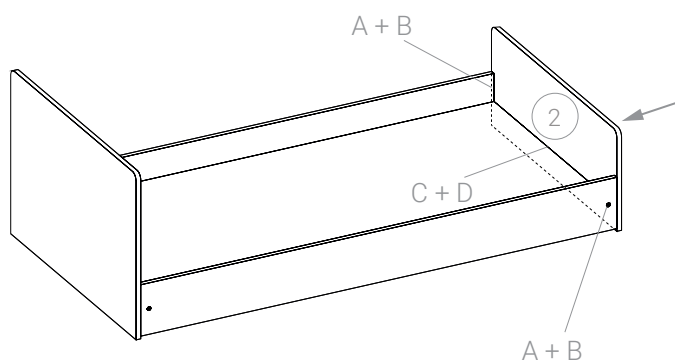
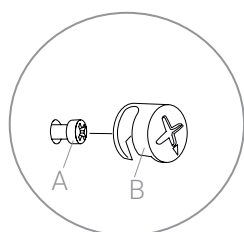

## PASO 9 / STEP 9

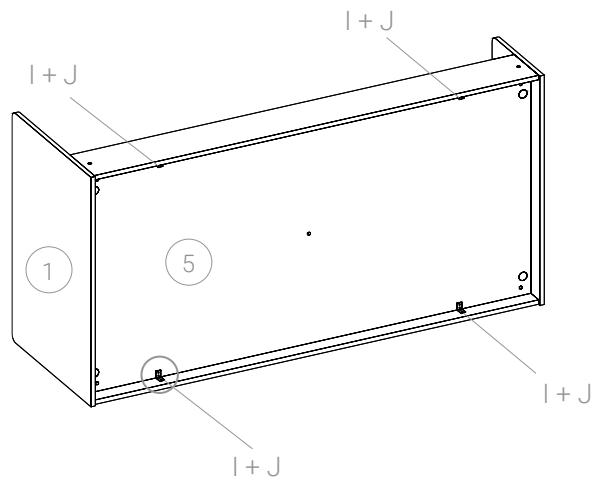
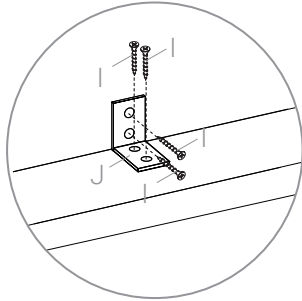
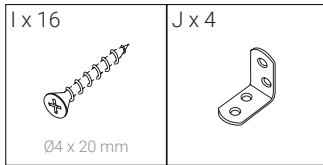

## PASO 10 / STEP 10

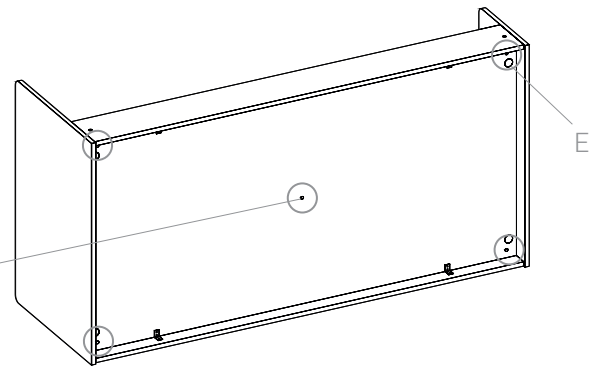
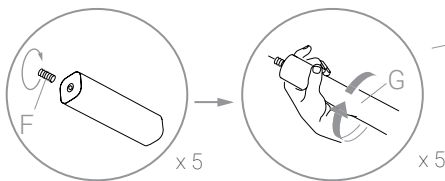
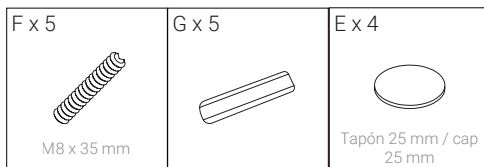

## PASO 11 / STEP 11

