

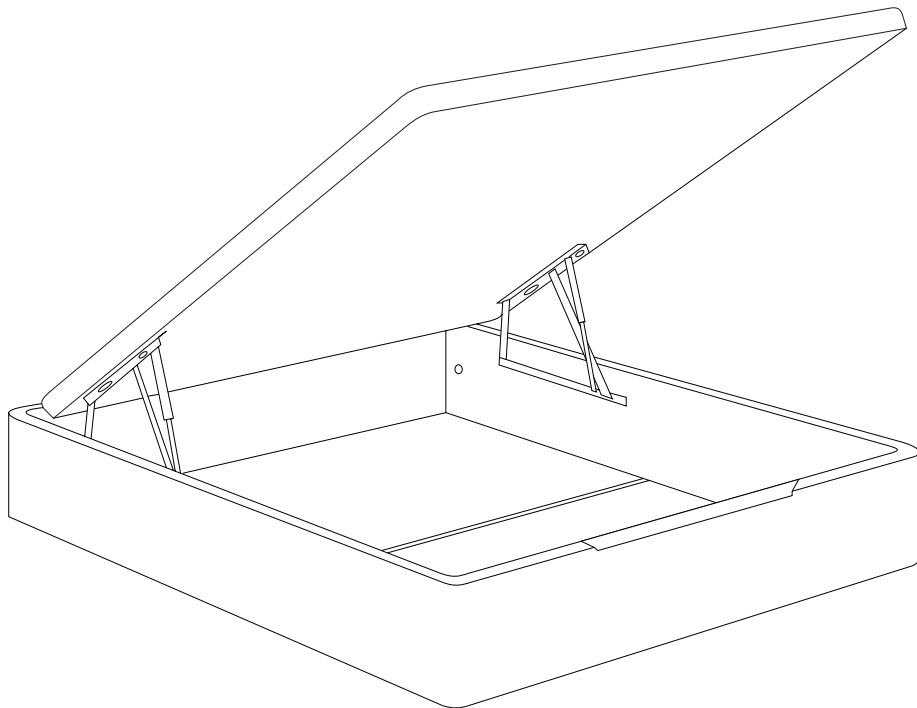









# KENAY

TRIP CANAPÉ  
TRIP STORAGE BED



Es muy importante seguir las fases de montaje y utilizar todos los herrajes enviados por fábrica.  
It is very important to follow every assembly stage. and use all hardware shipped by factory.

## PIEZAS / PIECES

|   |  |  |  |   |
|---|--|--|--|---|
| A x 8 uds<br>                | B x 4 uds<br> | C x 4 uds<br>               | H x 1 ud<br>  |   |
| D x 18 uds<br><br>M4 x 35 mm | E x 4 uds<br> | F x 6 uds<br><br>M8 x 20 mm | G x 6 uds<br> | I x 1 ud<br> |

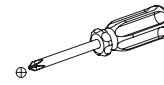

## HERRAMIENTAS / TOOLS



1. Revisar las piezas que constituyen el mueble.
2. Agrupar por tipos los herrajes.
3. Preparar los útiles necesarios.
4. Proteger la zona de montaje (moqueta o similar) para la protección de la madera.
5. Iniciar el montaje (no forzar los ensamblajes).
6. Se advierte de los riesgos inherentes a una instalación incorrecta.

1. Check each piece which forms the furniture.
2. Group by type of fitting.
3. Prepare the necessary tools.
4. Prepare the assembly area (carpet or similar) to protect the wood.
5. Begin the assembly (do not force the connections).
6. Be warned of risks due to incorrect installation.

## PASO 1/ STEP 1

|  |  |  |
|--|--|--|
| A x 8 uds<br> | B x 4 uds<br> | C x 4 uds<br> |
|--|--|--|

### PASO 1.1/ STEP 1.1

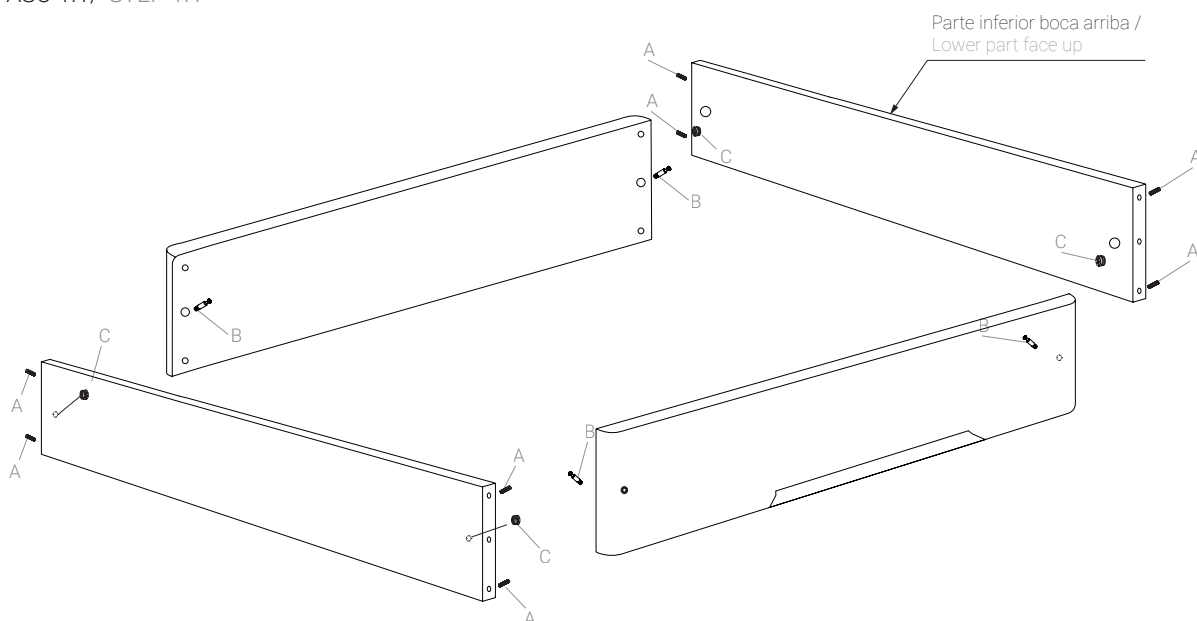

PASO 1.2/STEP 1.2

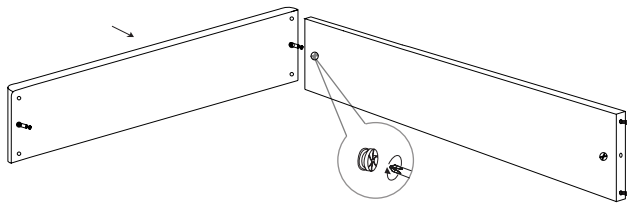

PASO 1.3/STEP 1.3

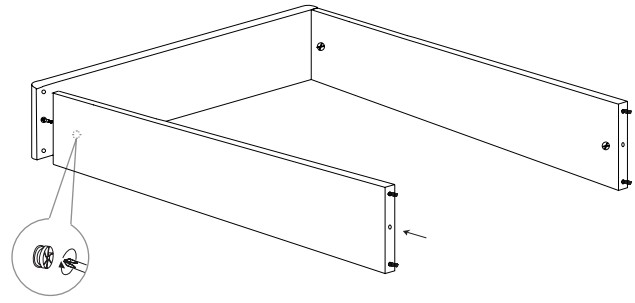

PASO 1.4 /STEP 1.4

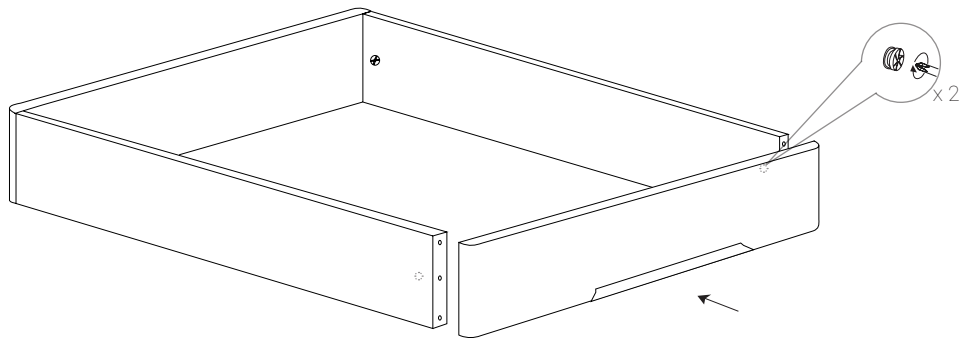

PASO 2 / STEP 2

PASO 2.1/ STEP 2.1

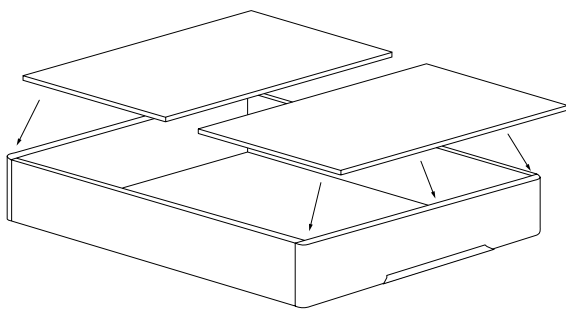





PASO 2.2 / STEP 2.2

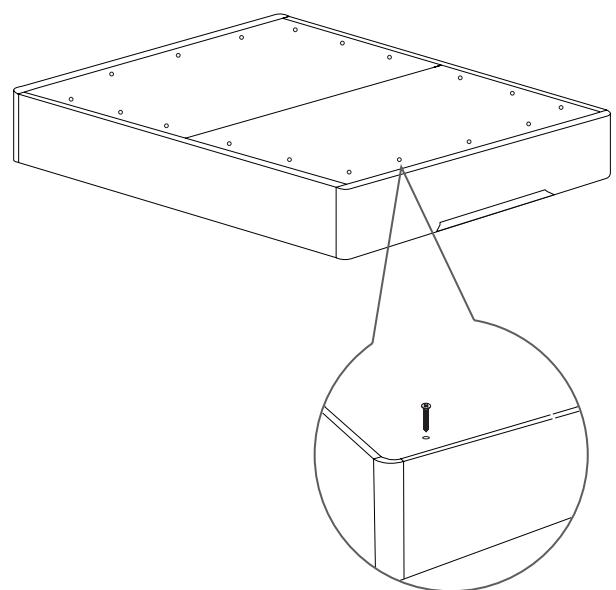

El número de tornillos varía según las medidas del canapé. Agujeros ya mecanizados /  
The number of screws varies according to the measurements of the couch. Pre-machined holes

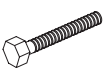

## PASO 3 / STEP 3

|  |  |  |   |
|--|--|--|---|
| <p>F x 6 uds</p>  <p>M8 x 20 mm</p> | <p>E x 4 uds</p>  | <p>G x 6 uds</p>  | <p>H x 1 ud</p>  |
|--|--|--|---|

### PASO 3.1/ STEP 3.1

x 2

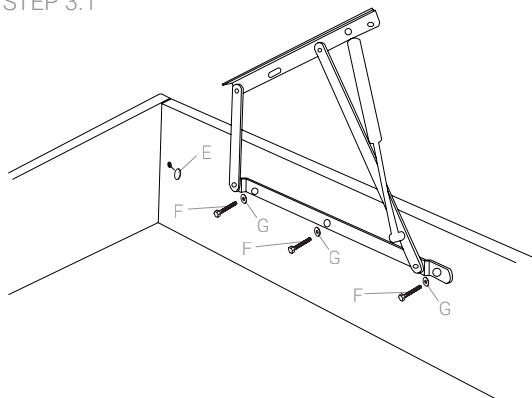

### PASO 3.2 / STEP 3.2

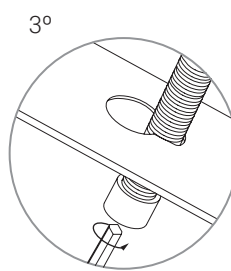
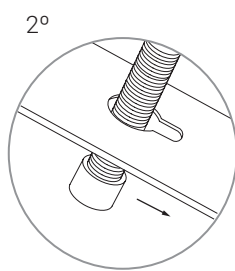
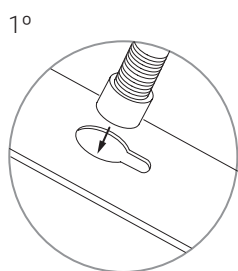
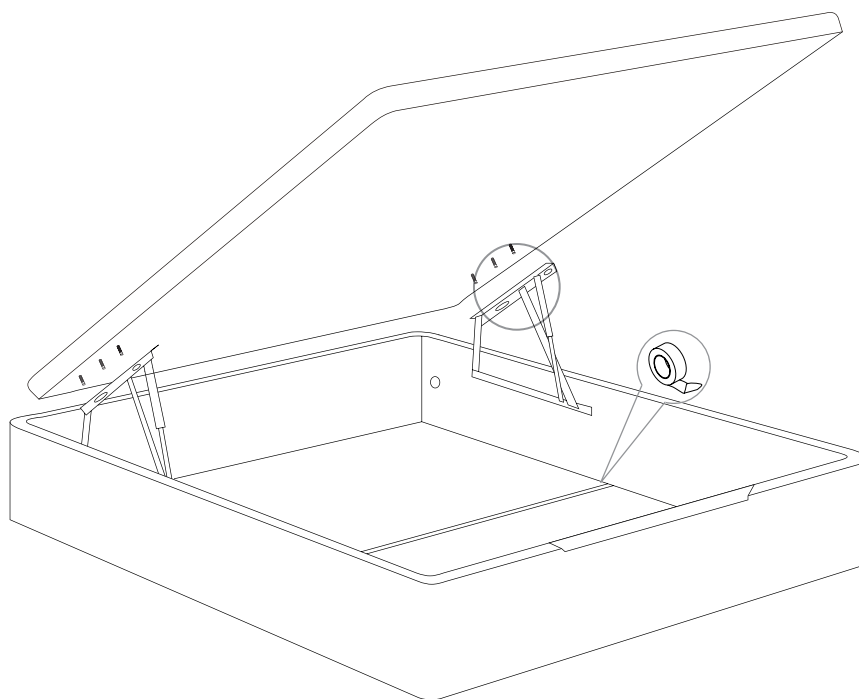

MONTAJE PARA CAMAS DE 135, 150 y 160 CM CON DOBLE TAPA SIN COSTILLA CENTRAL /  
 ASSEMBLY FOR BEDS 135, 150 and 160 CM WITH DOUBLE COVER WITHOUT CENTRAL COSTLE

PASO 1/ STEP 1

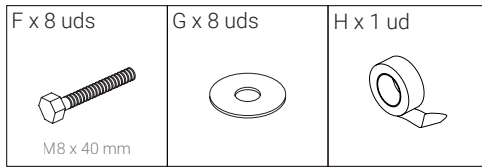

PASO 1.1/ STEP 1.1

Vista inferior. Ensamblaje tapas. /  
 Bottom view. Covers assembly.

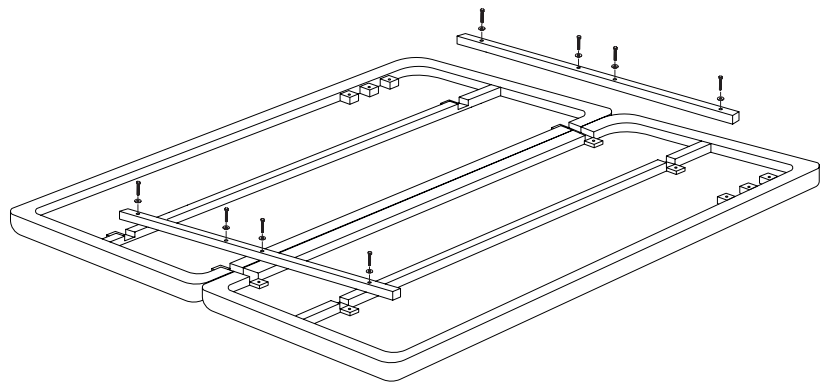
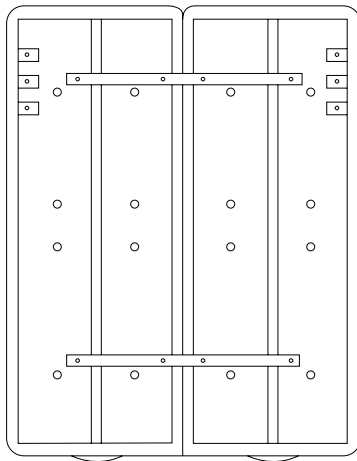

PASO 1.2/ STEP 1.2

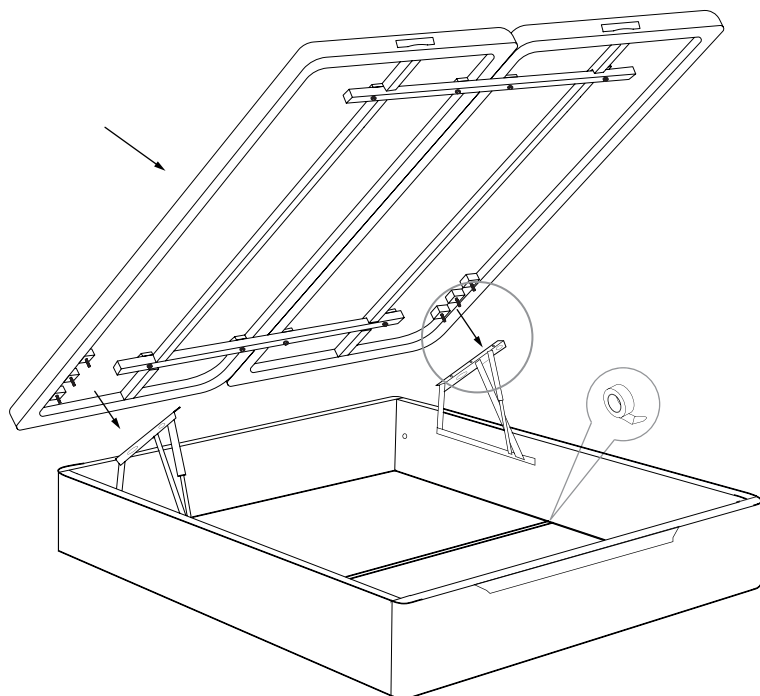
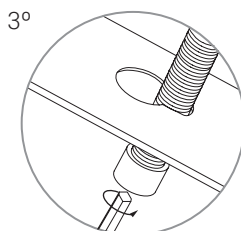
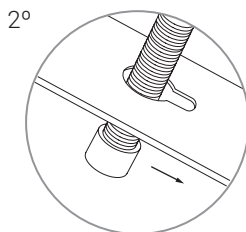
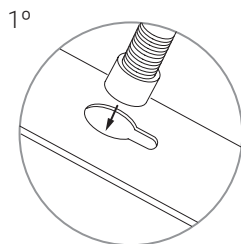

MONTAJE PARA CAMAS DE 160, 180 y 200 CM CON COSTILLA /  
ASSEMBLY FOR 160, 180 and 200 CM BEDS WITH COSTLE

PASO 1 / STEP 1

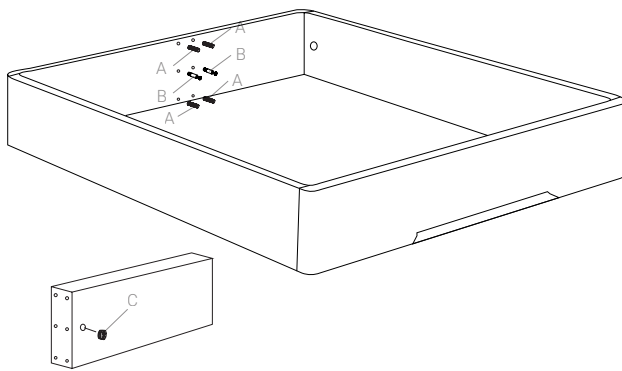
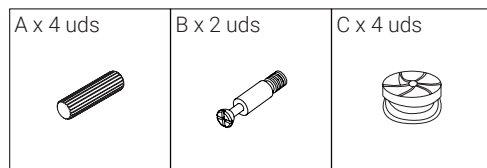

PASO 2 / STEP 2

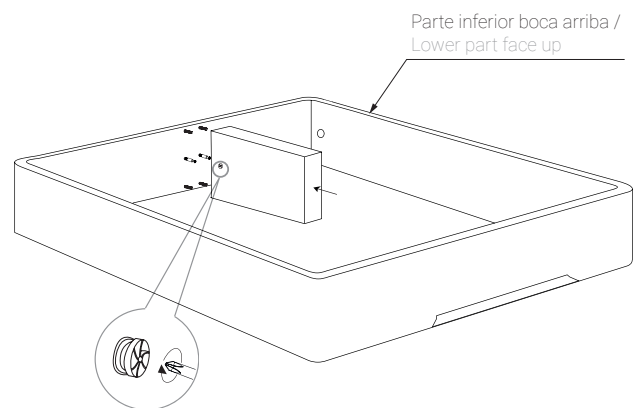

PASO 3 / STEP 3

PASO 3.1 / STEP 3.1

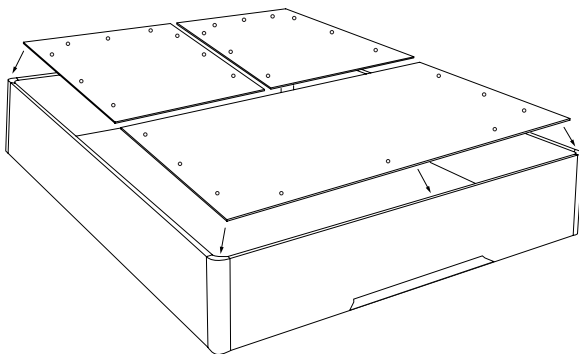

PASO 3.2 / STEP 3.2

D x 27 uds



M4 x 35 mm

El número de tornillos varía según las medidas del canapé. Agujeros ya mecanizados /  
The number of screws varies according to the measurements of the couch. Pre-machined holes

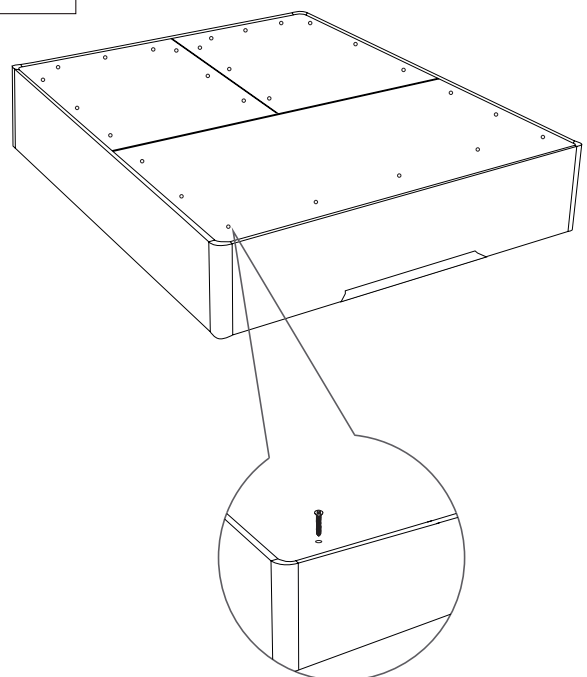

## PASO 4 / STEP 4

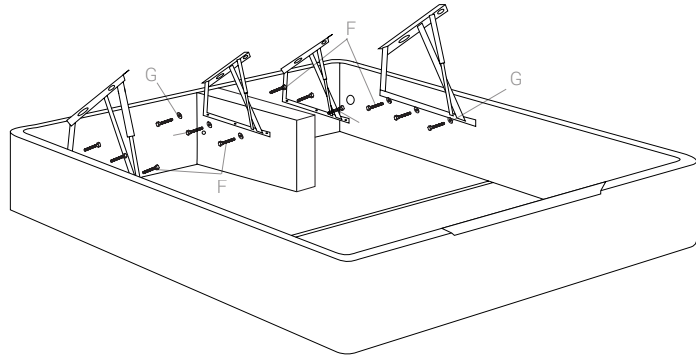
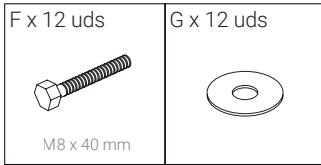

## PASO 5 / STEP 5

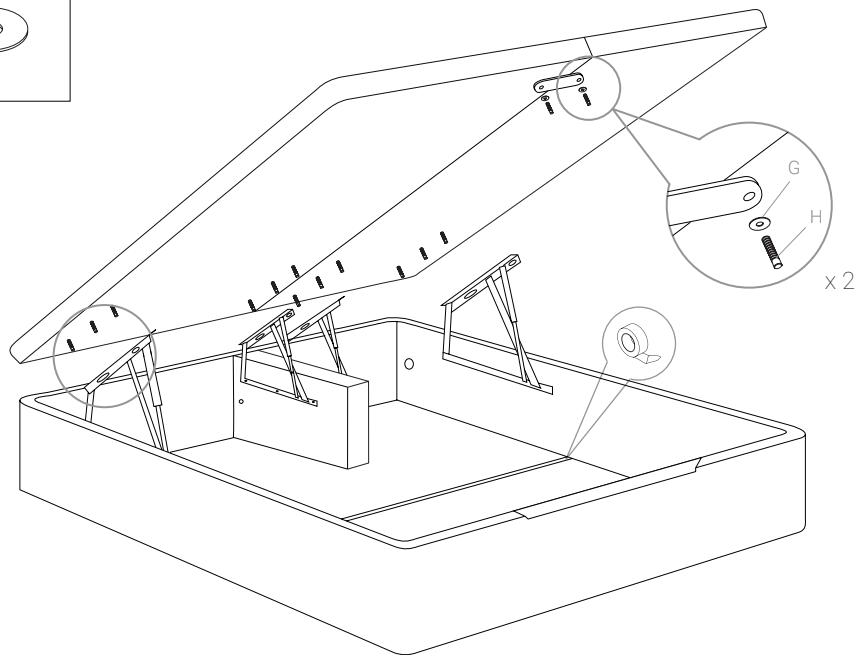
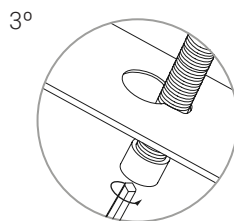
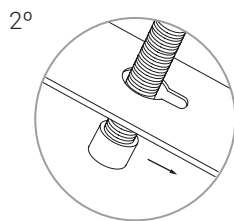
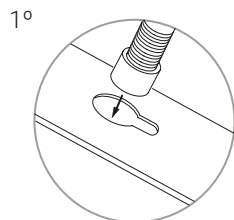
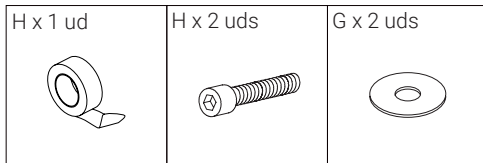

## PASO 6 / STEP 6

